

SHORT ANSWER. Write the word or phrase that best completes each statement or answers the question.

Find all solutions of the equation.

1) $\tan x = \frac{\sqrt{3}}{3}$ 1) _____

2) $\tan x \sec x = -2 \tan x$ 2) _____

Solve the equation on the interval $[0, 2\pi)$.

3) $\cos^2 x + 2 \cos x + 1 = 0$ 3) _____

4) $\cos x = \sin x$ 4) _____

5) $\sin^2 x - \cos^2 x = 0$ 5) _____

6) $\sin^2 x + \sin x = 0$ 6) _____

Two sides and an angle (SSA) of a triangle are given. Determine whether the given measurements produce one triangle, two triangles, or no triangle at all. Solve each triangle that results. Round lengths to the nearest tenth and angle measures to the nearest degree.

7) $A = 30^\circ, a = 22, b = 44$ 7) _____

Solve the triangle. Round lengths to the nearest tenth and angle measures to the nearest degree.

8) $A = 38^\circ$
 $B = 32^\circ$
 $a = 42.1$ 8) _____

Polar coordinates of a point are given. Find the rectangular coordinates of the point.

9) $(-5, -180^\circ)$ 9) _____

Solve the triangle. Round lengths to the nearest tenth and angle measures to the nearest degree.

10) $a = 8, b = 14, c = 16$ 10) _____

11) 11) _____

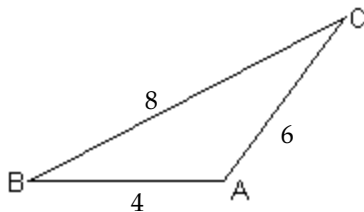

Solve the triangle.

12)

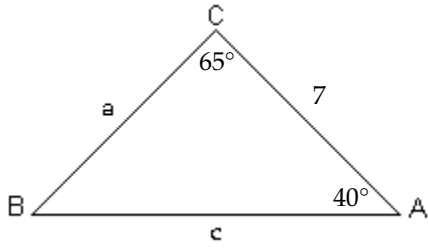

12) _____

Polar coordinates of a point are given. Find the rectangular coordinates of the point.

13) $(3, -135^\circ)$

13) _____

14) $\left(9, \frac{2\pi}{3}\right)$

14) _____

The rectangular coordinates of a point are given. Find polar coordinates of the point. Express θ in radians.

15) $(-4, 4)$

15) _____

16) $(2\sqrt{3}, 2)$

16) _____

17) $(-4\sqrt{2}, -4\sqrt{2})$

17) _____

Convert the rectangular equation to a polar equation that expresses r in terms of θ .

18) $x = 4$

18) _____

19) $x^2 + y^2 = 16$

19) _____

20) $(x - 16)^2 + y^2 = 256$

20) _____

21) $8x - 3y + 10 = 0$

21) _____

Convert the polar equation to a rectangular equation.

22) $\theta = \frac{2\pi}{3}$

22) _____

23) $r^2 \sin 2\theta = 4$

23) _____

24) $r = -3 \cos \theta$

24) _____

MULTIPLE CHOICE. Choose the one alternative that best completes the statement or answers the question.

The graph of a polar equation is given. Select the polar equation for the graph.

25)

25) _____

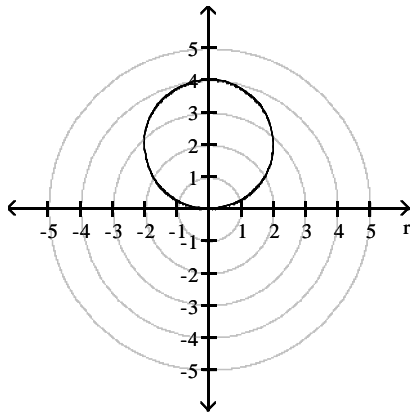

A) $r = 2$

B) $r \sin \theta = 2$

C) $r = 4 \cos \theta$

D) $r = 4 \sin \theta$

26)

26) _____

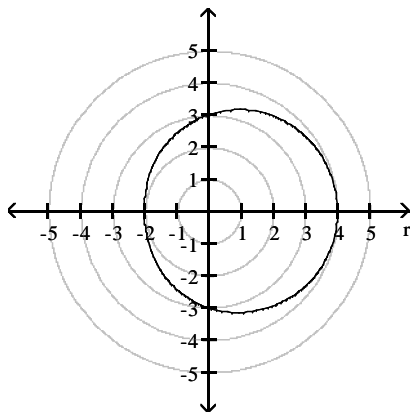

A) $r = 6 \cos \theta$

B) $r = 6 \sin \theta$

C) $r = 3 + \sin \theta$

D) $r = 3 + \cos \theta$

SHORT ANSWER. Write the word or phrase that best completes each statement or answers the question.

Find the absolute value of the complex number.

27) $z = -10 + 14i$

27) _____

28) $z = 3 + 9i$

28) _____

Write the complex number in polar form. Express the argument in radians.

29) $2 - 2i$

29) _____

Write the complex number in polar form. Express the argument in degrees.

30) $4i$

30) _____

Write the complex number in polar form. Express the argument in radians.

31) $-5\sqrt{3} - 5i$

31) _____

Write the complex number in rectangular form.

32) $5\left(\cos \frac{2\pi}{3} + i \sin \frac{2\pi}{3}\right)$

32) _____

Find the product of the complex numbers. Leave answer in polar form.

33) $z_1 = 7\left(\cos \frac{\pi}{4} + i \sin \frac{\pi}{4}\right)$
 $z_2 = 4\left(\cos \frac{\pi}{6} + i \sin \frac{\pi}{6}\right)$

33) _____

34) $z_1 = 4i$
 $z_2 = -6 + 6i$

34) _____

Find the quotient $\frac{z_1}{z_2}$ of the complex numbers. Leave answer in polar form.

35) $z_1 = 6\left(\cos \frac{3\pi}{2} + i \sin \frac{3\pi}{2}\right)$
 $z_2 = 12\left(\cos \frac{5\pi}{6} + i \sin \frac{5\pi}{6}\right)$

35) _____

36) $z_1 = \frac{1}{8}\left(\cos \frac{2\pi}{3} + i \sin \frac{2\pi}{3}\right)$
 $z_2 = \frac{1}{3}\left(\cos \frac{\pi}{4} + i \sin \frac{\pi}{4}\right)$

36) _____

37) $z_1 = 14(\cos 37^\circ + i \sin 37^\circ)$
 $z_2 = 2(\cos 6^\circ + i \sin 6^\circ)$

37) _____

Use DeMoivre's Theorem to find the indicated power of the complex number. Write the answer in rectangular form.

38) $(\cos 30^\circ + i \sin 30^\circ)^{12}$

38) _____

39) $\left[2\sqrt{2}\left(\cos \frac{7\pi}{4} + i \sin \frac{7\pi}{4}\right)\right]^5$

39) _____

40) $(1 + i)^{20}$

40) _____

Find all the complex roots. Write the answer in the indicated form.

41) The complex square roots of $2\left(\cos \frac{2\pi}{3} + i \sin \frac{2\pi}{3}\right)$ (rectangular form)

41) _____

42) The complex cube roots of 8 (rectangular form)

42) _____

43) The complex cube roots of -8 (rectangular form)

43) _____

44) The complex cube roots of 8i (rectangular form)

44) _____

45) The complex cube roots of $-8i$ (rectangular form)

45) _____

46) The complex square roots of i (rectangular form)

46) _____

47) The complex fourth roots of -16 (rectangular form)

47) _____

Answer Key

Testname: PRACTICE TEST III

1) $x = \frac{\pi}{6} + n\pi$

2) $x = \frac{2\pi}{3} + 2n\pi$ or $x = \frac{4\pi}{3} + 2n\pi$ or $x = n\pi$

3) π

4) $\frac{\pi}{4}, \frac{5\pi}{4}$

5) $\frac{\pi}{4}, \frac{3\pi}{4}, \frac{5\pi}{4}, \frac{7\pi}{4}$

6) $0, \pi, \frac{3\pi}{2}$

7) $B = 90^\circ, C = 60^\circ, c = 38.1$

8) $C = 110^\circ, b = 36.2, c = 64.3$

9) $(5, 0)$

10) $A = 30^\circ, B = 61^\circ, C = 89^\circ$

11) $A = 104^\circ, B = 47^\circ, C = 29^\circ$

12) $B = 75^\circ, a = 4.66, c = 6.57$

13) $\left(\frac{-3\sqrt{2}}{2}, \frac{-3\sqrt{2}}{2} \right)$

14) $\left(-\frac{9}{2}, \frac{9\sqrt{3}}{2} \right)$

15) $\left(4\sqrt{2}, \frac{3\pi}{4} \right)$

16) $\left(4, \frac{\pi}{6} \right)$

17) $(8, 225^\circ)$

18) $r = \frac{4}{\cos \theta}$

19) $r = 4$

20) $r = 32 \cos \theta$

21) $r = \frac{-10}{(8 \cos \theta - 3 \sin \theta)}$

22) $y = -\sqrt{3}x$

23) $xy = 2$

24) $\left(x + \frac{3}{2} \right)^2 + y^2 = \frac{9}{4}$

25) D

26) D

27) $2\sqrt{74}$

28) $3\sqrt{10}$

29) $2\sqrt{2} \left(\cos \frac{7\pi}{4} + i \sin \frac{7\pi}{4} \right)$

30) $4(\cos 90^\circ + i \sin 90^\circ)$

31) $10 \left(\cos \frac{7\pi}{6} + i \sin \frac{7\pi}{6} \right)$

Answer Key

Testname: PRACTICE TEST III

$$32) -\frac{5}{2} + \frac{5\sqrt{3}}{2}i$$

$$33) 28 \left(\cos \frac{5\pi}{12} + i \sin \frac{5\pi}{12} \right)$$

$$34) 24\sqrt{2} \left(\cos \frac{5\pi}{4} + i \sin \frac{5\pi}{4} \right)$$

$$35) \frac{1}{2} \left(\cos \frac{2\pi}{3} + i \sin \frac{2\pi}{3} \right)$$

$$36) \frac{3}{8} \left(\cos \frac{5\pi}{12} + i \sin \frac{5\pi}{12} \right)$$

$$37) 7(\cos 31^\circ + i \sin 31^\circ)$$

$$38) 1$$

$$39) -128 + 128i$$

$$40) -1024$$

$$41) \frac{\sqrt{2}}{2} + \frac{\sqrt{6}}{2}i, -\frac{\sqrt{2}}{2} - \frac{\sqrt{6}}{2}i$$

$$42) 2, -1 + \sqrt{3}i, -1 - \sqrt{3}i$$

$$43) -2, 1 + \sqrt{3}i, 1 - \sqrt{3}i$$

$$44) -2i, \sqrt{3} + i, -\sqrt{3} + i$$

$$45) 2i, -\sqrt{3} - i, \sqrt{3} - i$$

$$46) \frac{\sqrt{2}}{2} + \frac{\sqrt{2}}{2}i, -\frac{\sqrt{2}}{2} - \frac{\sqrt{2}}{2}i$$

$$47) \sqrt{2} + \sqrt{2}i, \sqrt{2} - \sqrt{2}i, -\sqrt{2} + \sqrt{2}i, -\sqrt{2} - \sqrt{2}i$$